

# Passage Niki Set Installation Guide

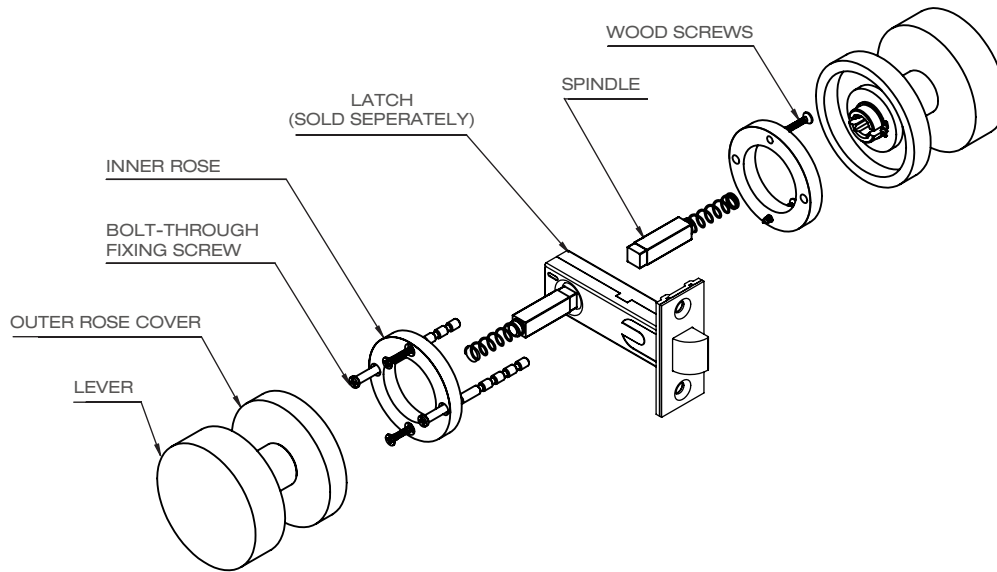

## Items Provided With Passage Sets

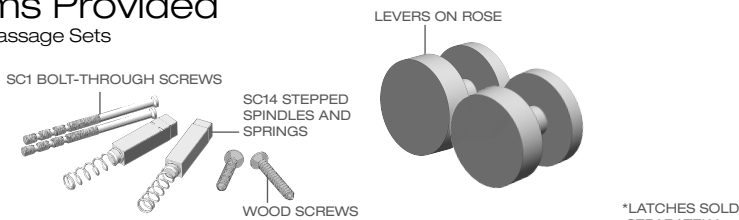

## Items Not Provided Suggested tools to be used

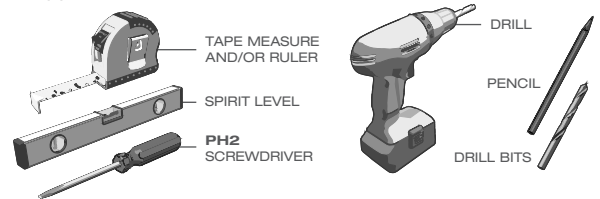

## Care and Maintenance Guide

### Brass Based Products

#### Maintenance

Finishes on all products are produced to the highest quality standards to ensure they remain in perfect order year after year. However some finishes can deteriorate if they are exposed to corrosive vapors, coastal air, salt spray or humidity. Soft finishes, which include polished brass, polished chrome and satin chrome, are susceptible to discolouration if they come into contact with air, moisture, or paint, particularly in exterior locations and wet areas. To help slow deterioration, it is suggested to regularly wipe these finishes with a soft non-abrasive cloth and occasionally polish with a furniture wax.

### Stainless Steel

#### Care and Maintenance

There are many advantages with stainless steel, but it is steel, and steel does rust. Regardless of grade, cleaning is paramount, especially in coastal areas. The aesthetic and hygienic surface appearance of stainless steel products cannot be regarded as completely maintenance free. All grades and finishes of stainless steel may in fact stain, discolour or attain an adhering layer of grime in normal service. To achieve maximum corrosion resistance, the surface of the stainless steel must be kept clean. The cost and frequency of cleaning stainless steel is lower than for many other materials. Surface contamination and the formation of deposits are critical factors that may lead to drastically reduced life. These contaminants may be minute particles of iron or rust from other non-stainless steel items nearby, industrial, commercial, domestic and naturally occurring atmospheric conditions can result in deposits, which can be quite corrosive. An example is salt deposits from marine conditions.

#### Maintenance During Installation

Cleaning of new handles should not present any special problems, although more attention may be required if the installation period has been prolonged. Where surface contamination is suspected, immediate attention to cleaning will promote a trouble-free service life.

#### Ongoing Maintenance

To keep the original appearance of the product ongoing maintenance must be conducted once the surface appears dirty. This may vary from between approximately one to four times a year for external applications or it may be once a day for an item in hygienic or aggressive situations. Stainless steel is easy to clean. Washing with soap or a mild detergent and warm water followed by a clean water rinse is usually adequate for domestic and architectural situations. Rust and other corrosion can be removed by adding one part nitric acid to nine parts warm water. Leave for 30 to 60 minutes, then wash off with plenty of water. For slight scratches - use impregnated nylon pads (Scotch-Brite®) following satin lines.

The choice of a proper cleaning product is based upon the user's own preferences. Depending on the type of cleaning and level of contamination, some products are better than others. Although some products are called "stainless steel cleaners", they may scratch the surface, and many contain chlorine bleach that will dull, tarnish, or discolour the surface if not completely removed. We recommend Eagle One Nev-Dull® (available from Designer Doorware). We also reiterate that the mildest cleaner possible should be used for the particular task. Rubbing should follow the satin lines of the steel and always ensure the surface is thoroughly rinsed after cleaning. For routine cleaning (as indicated above), the cleaning products most recommended are gentle soaps and detergents or mild mixtures of ammonia.

#### Living Finishes

SBU, PBU, ABM, ABD, FBM, FBD, ORB, WBL, WBM

Designer Doorware's living finishes are fabricated and coloured by hand; variations in size, shape, and colour are a natural result of this process. Tooling marks and surface scratches are part of the character of the finished pieces. Most products are sealed with wax, which over time is not impervious to moisture and corrosion or wear and tear. The standard wax coating allows the finish to age naturally and develop its own character and morph into the environment wearing off where it is used most exposing the natural material underneath, this will patina with time and become a living finish. Due to the artisan, hand-made nature of these finishes, every product is unique. While we aim for consistency, there will always be a degree of variance with living finishes. Do not use methylated spirits on any products with a living finish, as it may strip away any aesthetic or protective coating.

#### Plated, PVD & PCC Finishes

SC, PC, SM, PN, SBC, BC, VGM, FCC, BKA, VBK

Do not use harsh solvents, abrasives cleaners or scourers on any Designer Doorware products as this may affect the thickness of protective coatings such as plating and powder-coating. Also note that powder-coated finishes may chip with rough handling, and therefore caution should be taken during maintenance and use.

## Warranty Information

### Product Guarantee

Designer Doorware Pty Ltd guarantees their products against defects in workmanship and materials. If the product is found to be defective, Designer Doorware will repair or supply the same or an equivalent product free of charge in accordance with the terms and conditions of the country of sale. Brass and all plated finishes are classified as soft finishes; as deterioration is possible under some climatic conditions, these are excluded for this guarantee. Any modifications to a product as supplied, or repairs are excluded from this guarantee.

### Claims

Any shortage or damage claims must be made within 7 days of the date of receipt of goods.

### Product Design

In the interest of constantly improving products, we reserve the right to alter dimensions, materials and designs at any time.

## Contact Us

t + 61 3 9300 8888  
f + 61 3 9310 1866  
sales@designerdoorware.com.au  
designerdoorware.com.au

7 Kimpton Way, Altona, Victoria,  
Australia, 3018

**Showroom**  
431 Church St, Richmond, Victoria,  
Australia, 3121

## Prepare Door

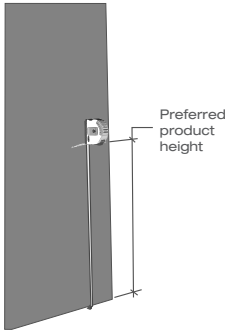

Preferred product height

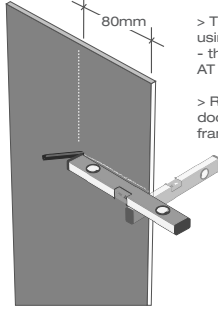

> Determine your nominated handle position vertically using a tape measure.

> Then, draw a horizontal centerline using a spirit level at desired height - this line should extend inwards AT LEAST 80mm from door edge.

> Repeat above steps on opposite door side, door end-face and door frame.

dD suggests between 900-1000mm for typical new plain door installations.

1. 2.

## Drill Door Holes

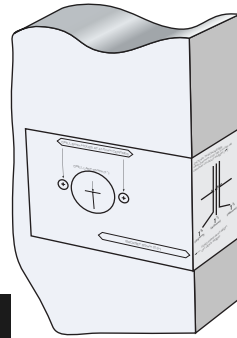

- > Using the template attached, mark drill centres [A - D] using a sharp pencil.
- > Remove template and measure the backset (edge of door to centre of hole A) which should be 60mm.
- > Repeat steps above on opposite door face.
- > Drill holes [A - D] (in that order) as marked on template.

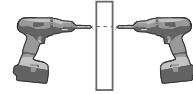

DRILL ONE SIDE AND FINISH FROM OTHER SIDE TO PREVENT SPLITTING



## Prepare Door Frame

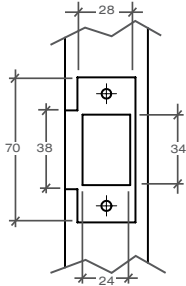

> Using the preferred method, create a 28mm x 70mm, 2.5mm deep, recess in door frame, and cut out a 38mm x 2.5mm deep recess for the striker tongue centred at the preferred height specified in Step 1.

> Finally, create a 24mm x 34mm hole, 12mm deep to house the dustbox.

3. 4.

## Install Striker Plate

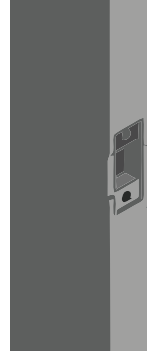

> Place the dustbox into the door frame and secure with the striker plate and provided striker wood screws.

## Install Latch

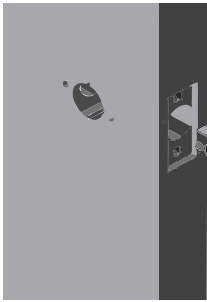

> Using preferred method, make a 25mm x 57mm, 4.5mm deep, recess in door end centred on the latch hole for the forend and face plate.

> Insert latch mechanism into hole and secure to surface with wood screws provided, securing face plate on the front.

Face Plate secured on front

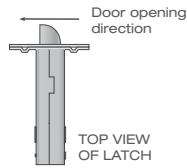

5. 6.

## Prepare Screws

CUT SC1 SCREWS APPROPRIATE TO DOOR THICKNESS (32-52mm)



LONGER SC2 AND SC84 SCREWS AVAILABLE ON REQUEST FOR THICKER DOORS

- > Based on door thickness, cut required screws to suit.
- > Ensure the screw does not stick out of the rose once installed.

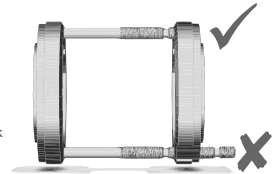

## Install Inner Roses

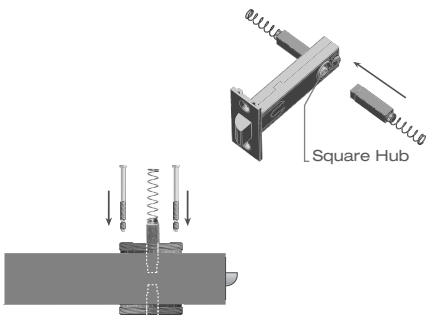

> Place the stepped spindles and springs into the latch as shown.

> Install each inner rose on either side.

> Insert two cut off screws of correct length through holes at 9 and 3 o'clock positions and tighten.

> The two remaining woodscrews can be positioned at the 12 and 6 o'clock positions for added strength.

7. 8.

## Install Lever & Outer Rose

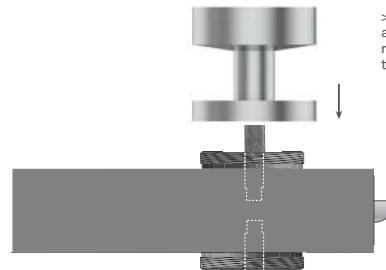

> Install the outer rose which is attached to the knob. The outer rose should simply screw onto the inner rose.

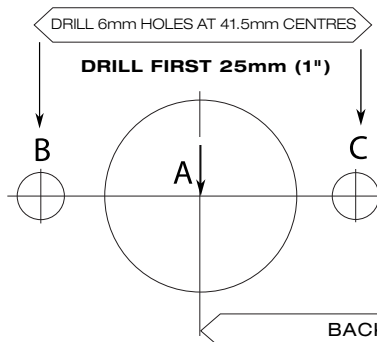

DOOR THICKNESS  
drill ø25mm (1"), 75mm deep  
hole at centre of door edge [↖]

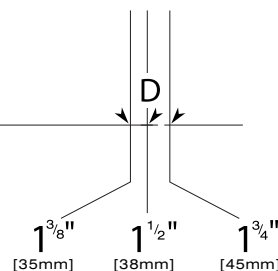

Fold here and align on door edge

CUT ALONG DOTTED LINE