

ML MORTICE LOCK INSTALLATION INSTRUCTIONS

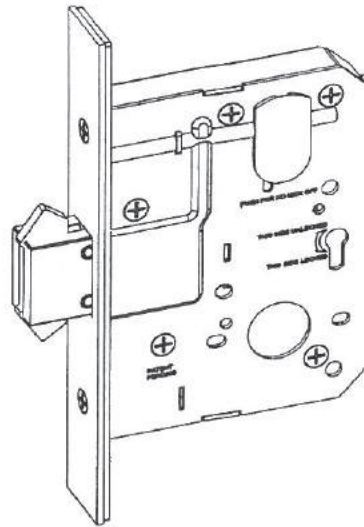

HANDING OF DOOR - BRITISH STANDARDS

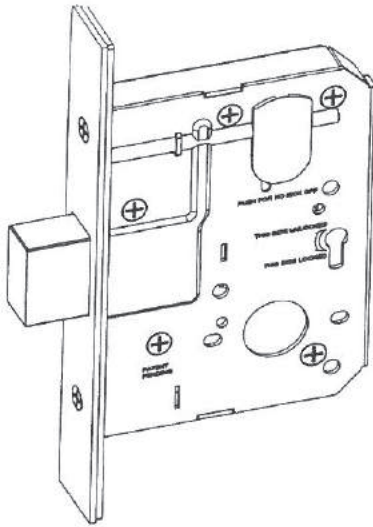
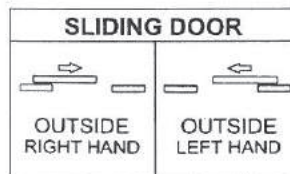
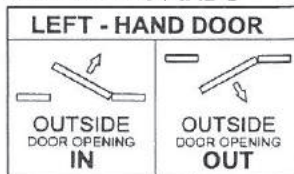
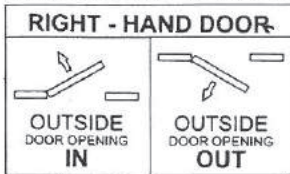

Head Office
7 Kimpton Way, Altona, Victoria, Australia, 3018
t +61 3 9300 8888

Showroom
431 Church St, Richmond, Victoria, Australia, 3121
w designerdoorware.com.au

MORTICE INSTRUCTIONS

- Determine centre line and height of installation on door.
- Place template on door and align with centre line, mark out cylinder holes and mortice cavity. Drill mortice cavity and cylinder holes to desired depth.
- Clean out mortice and insert lock case to check desired cavity size.
- Mark around front plate for face plate recess. Remove lock case from cavity and cut recess for face plate. Face plate must be flush with the door.
- Clean out cavity and install lock case and cylinders.

**NOTE: REMOVE LOCK FROM DOOR BEFORE DRILLING*

STRIKE INSTALLATION

- Mark out frame for strike and strike box if applicable.
- Cut out recess in door frame for flush installation.
- Install strike with screws provided.

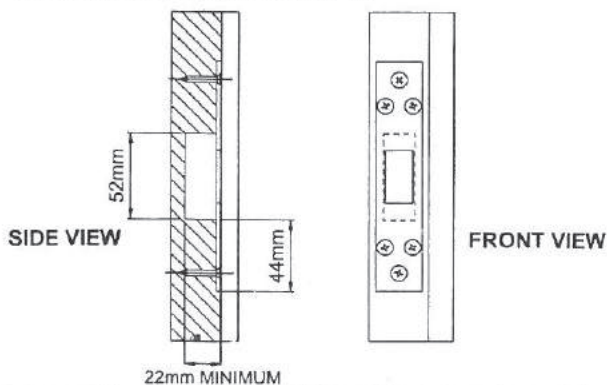

INSTALLATION OF LOCK AND CYLINDER

- Remove plastic cylinder cover cap with small flat blade screwdriver.
- Install lock in mortice and insert cylinder with Cam N fitted.
- Insert retaining pin to secure cylinder - ensure pin is flush with front plate.
- Install face plate with (2) metal thread screws provided.

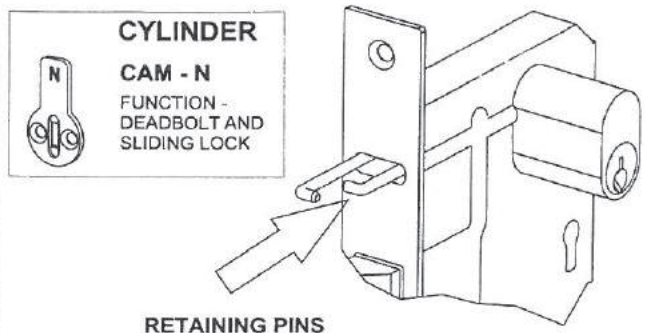

Guarantee

Designer Doorware guarantees its products against defects in workmanship and materials, subject to fair wear and tear for a minimum period of 2 years from date of installation.

Designer Doorware, however, assumes no liability for any of the following:

- Improper installation or failure to follow installation instructions.
- Failure due to improper maintenance.
- Indirect or inconsequential loss or damage.
- Cost of removal and/or replacement.
- Cost of freight and/or traveling time.

CAUTION! ONLY DRILL THE HOLES THAT YOU REQUIRE TO SUIT YOUR LOCK FUNCTION

60mm BACKSET

60mm BACKSET

DRILL FROM BOTH SIDES OF THE DOOR TO PREVENT DAMAGE TO THE DOOR

RECOMMENDED MINIMUM DOOR THICKNESS = 40mm
MAXIMUM DOOR GAP = 4mm

ML MORTICE LOCK FITTING TEMPLATE

DRILL 7 HOLES 20mm DIA x 90mm MINIMUM DEPTH

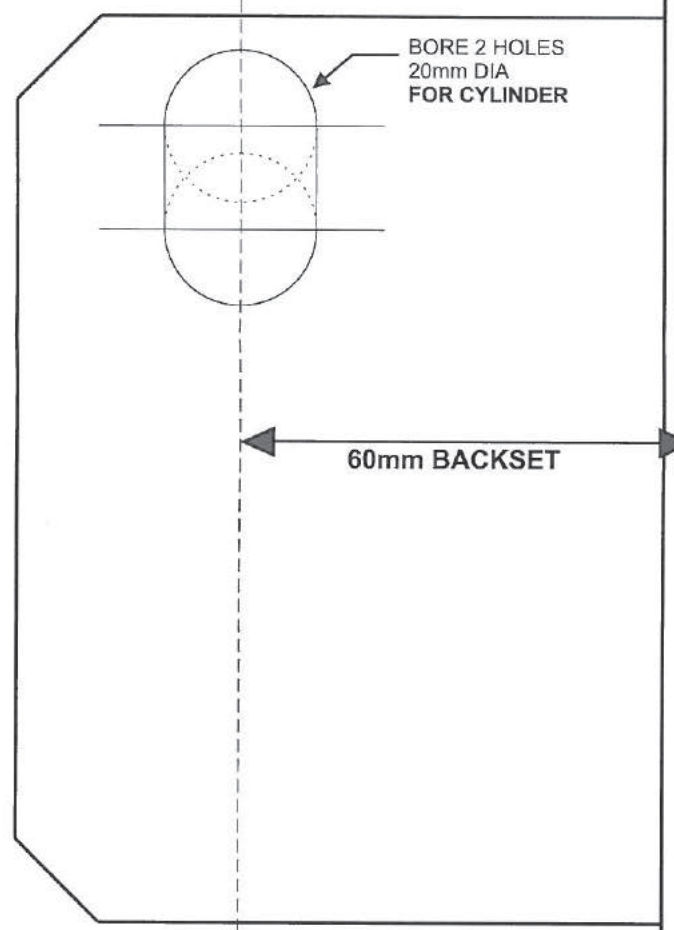

BORE 2 HOLES
20mm DIA
FOR CYLINDER

60mm BACKSET

FOLD ALONG DOTTED LINE AND ALIGN TEMPLATE WITH EDGE OF DOOR FOR 60mm BACKSET

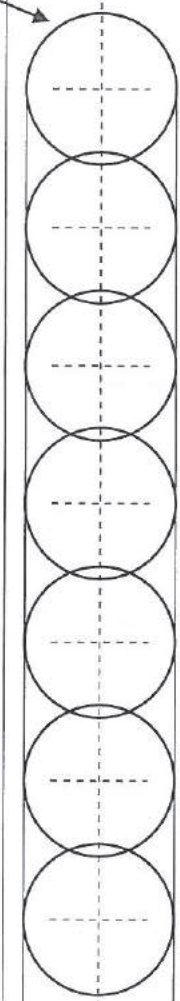

FOLD ALONG DOTTED LINE AND ALIGN TEMPLATE WITH EDGE OF DOOR FOR 60mm BACKSET

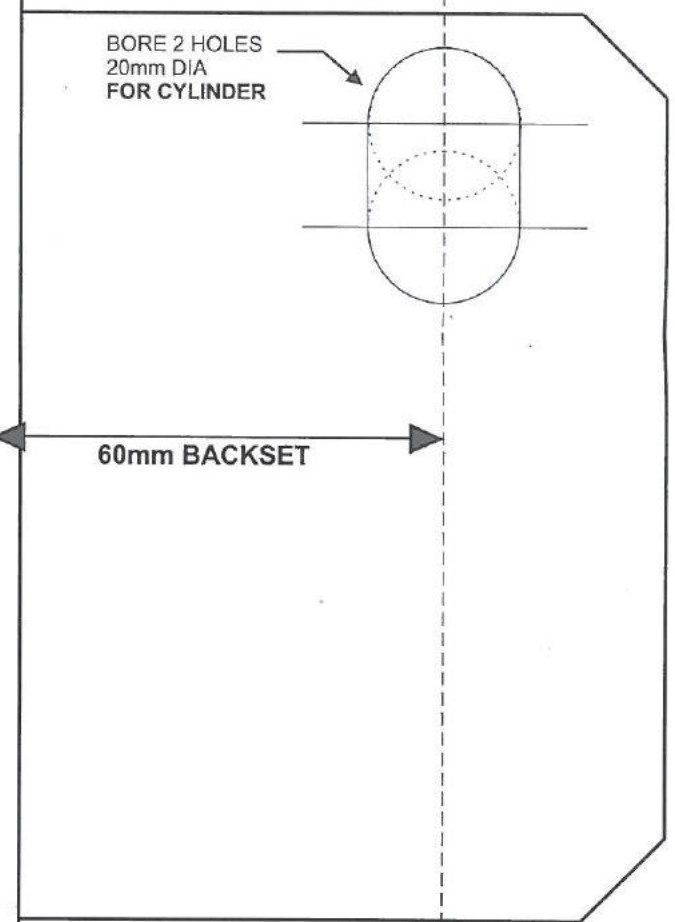

BORE 2 HOLES
20mm DIA
FOR CYLINDER

60mm BACKSET

BOTTOM EDGE OF FACEPLATE MORTICE

BOTTOM EDGE OF FACEPLATE MORTICE