

HANDING OF DOOR - ENGLISH STANDARDS

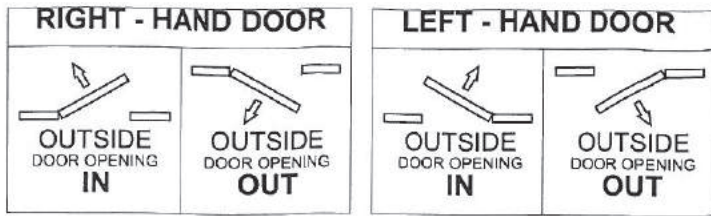

Important:
Before drilling door, ensure correct hand is being installed

Note:
Case does not need to be opened at any time to change function or handing of this lock

1 Door Preparation

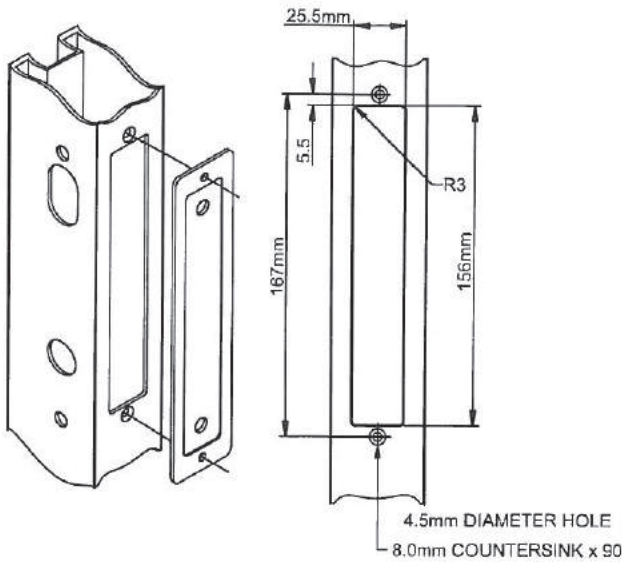

METAL DOOR PREPARATION

- 1) Determine the height of the lockset on the door.
- 2) Cut window 156mm x 25.5mm with a 3mm radius.
- 3) Place template in opening and drill 4.5mm holes, countersink with 8mm diameter at 90°.
- 4) Drill other appropriate holes for the selected lockset.

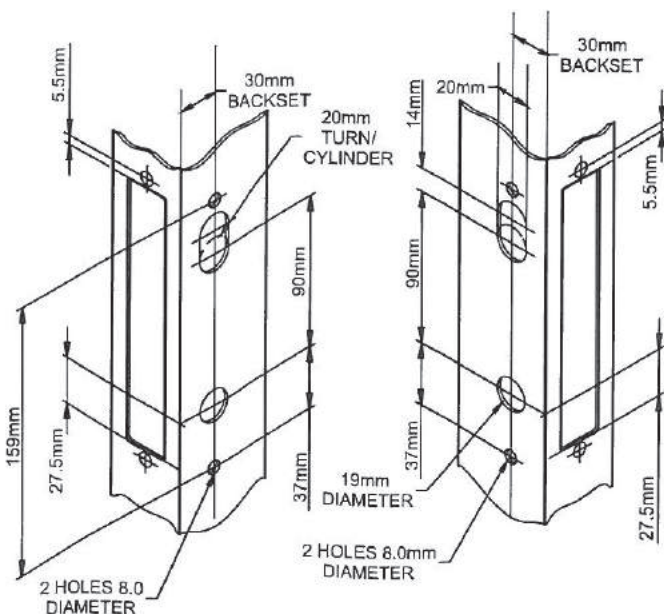

2

Lock Preparation

CHECK THE LOCK STATUS

Ensure that the locking bar is in unlocked position (UP). If position needs to be changed to the unlock position, use a small flat blade screwdriver to lever out plastic cylinder hole dust cap (where fitted) and lift locking bar using screwdriver.

Lock Functions

Depending on the locking function required it can be set to any vestibule or combination lock status. To change the locking function, it is necessary to use a small flat blade screw driver to rotate (*Anti-Clockwise Only*) the locking wedge to desired location. Refer to Lock Status Label on lock body for further detail.

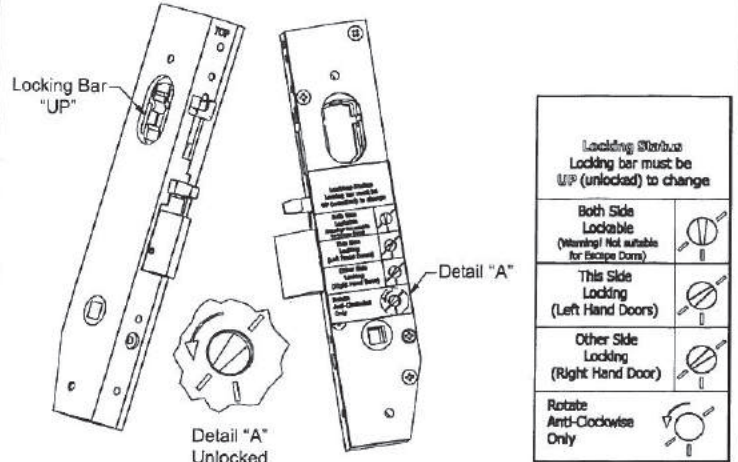

REVERSE BOLT HEAD

Determine the hand of lock from the Hand of Door chart. Rotate bolt head if required by removing Face Plate to pull and rotate the bolt 180° to suit the Latching direction.

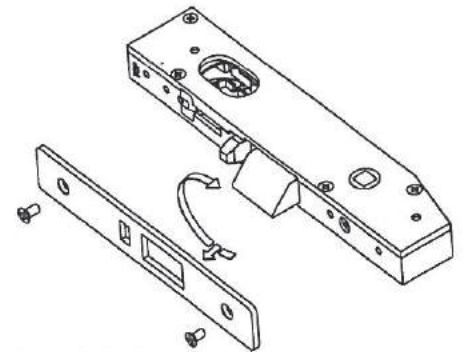

TURN ADAPTOR INSTALLATION

Designer Doorware turn adaptors are captive adaptors and must be installed correctly for proper lock operation.

1. Determine handing for adaptor.
2. Put lock into LOCKED STATUS by moving locking bar into down position.
3. Insert adaptor as per the illustration (A) ensuring the cam plate is engaged in the locking bar.
4. Insert retaining pin and test operation, ensuring the locking bar is operating up & down with operation of cam (Maximum 1/4 turn Left or Right).
5. Lock can now be left in UN-LOCKED STATUS, locking bar Up until installed on door.

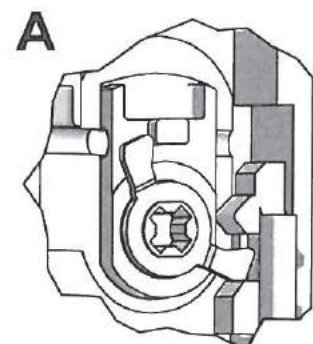

3

Lock Installation

FIT LOCK

Insert lock into door and secure with 2 screws.

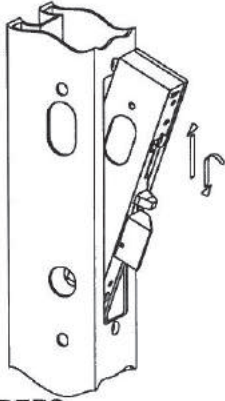

LOCKS WITH CYLINDERS

1. Using a small flat screwdriver, lever out Cylinder Hole Plug, where fitted. Insert lock into door and secure with 2 screws.
2. Secure cylinder with Retainer pin, ensuring pin is flush with front face of lock.
3. Install face plate and secure with 2 screws.

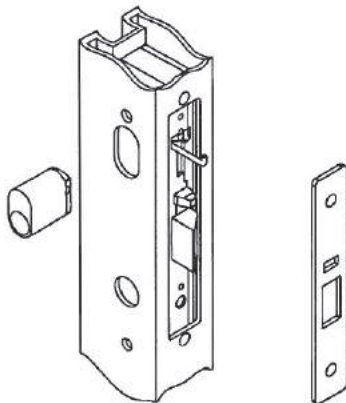

LOCKS WITHOUT CYLINDERS

Install face plate and secure with 2 screws.

LOCKS WITH TURNKNOB

Mark and cut the connecting bar as shown. Turnknob to be in the vertical position when unlocked.

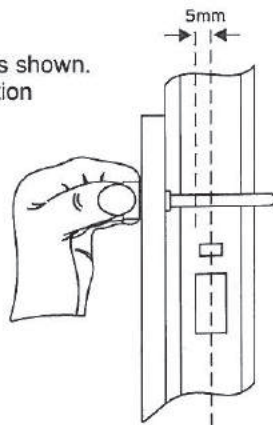

LOCKS WITH SPINDLE

Insert spindle/s into lock as required, ensuring the spindle spring is attached to the rear of spindle before assembling.

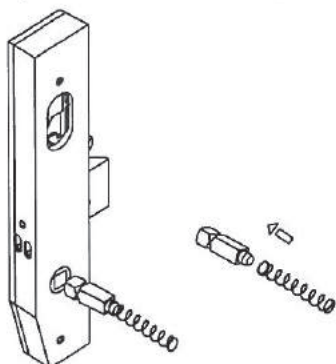

4

Finishing Installation

FIT FURNITURE

Rotate handle to the desired hand as shown. Cut the furniture screws 5mm past the door face (for doors thinner than 44mm). Position furniture plates and secure with mounting screws.

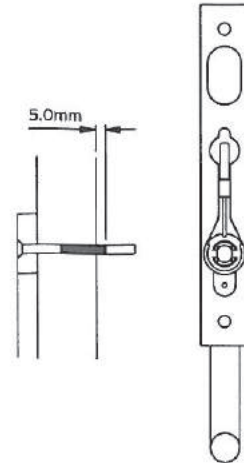

FIT MOUNTING STRIKE

Prepare doorjamb cutout, fit Strike-Box to frame. Fit Strike to Strike-Box & secure with 2 screws.

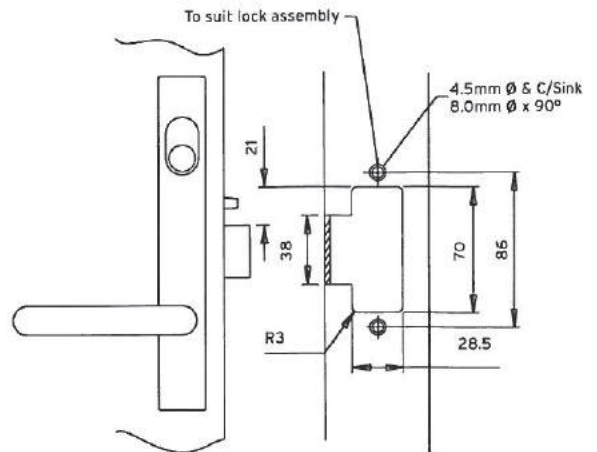

Guarantee

Designer Doorware guarantees its products against defects in workmanship and materials, subject to fair wear & tear for a minimum period of 2 years from date of installation.

Designer Doorware, however assumes no liability for any of the following:

- A. Improper installation or failure to follow Installation instructions.
- B. Failure due to improper maintenance.
- C. Indirect or inconsequential loss or damage.
- D. Cost of removal and/or replacement.
- E. Cost of freight and/or traveling time.



Head Office
7 Kimpton Way, Altona, Victoria, Australia, 3018
t +61 3 9300 8888

Showroom
431 Church St, Richmond, Victoria, Australia, 3121

w designerdoorware.com.au